

Configuration	4-stroke, vertical, water cooled diesel engine
Maximum output at crankshaft	390 kW (530 hp) @ 2900 rpm
Continuous rating output at crankshaft	368 kW (500 hp) @ 2800 rpm
Displacement	7.413 L (452 cu in)
Bore x stroke	110 mm x 130 mm (4.33 in x 5.12 in)
Cylinders	6 in-line
Combustion system	Direct injection
Aspiration	Turbocharged with air cooler
Starting system	Electric starting 12 V
Alternator	12 V - 120 A
Cooling system	Fresh water cooling by centrifugal fresh water pump and rubber impeller seawater pump
Lubrication system	Enclosed, forced lubricating system
Direction of rotation (crankshaft)	Counter clockwise viewed from flywheel side
Dry weight without gear	837 kg (1845 lb)
Environmental	EU RCD, US EPA Tier2, BSO II & EMC
Engine mounting	Rubber type flexible mounting

NOTE: Fuel condition: Density at 15°C = 0.84 g/cm³; 1kW = 1.3596 mhp = 1.3410 Hp
 Fuel temperature 40°C at the inlet of the fuel injection pump (ISO 8665: 2006)

Dimensions (For detailed line-drawings, please refer to our web-site: www.yanmarmarine.com)



6CX-530 with KMH70A

Performance Curves (Output is according ISO 8665 - Output includes +/- 3% tolerance)

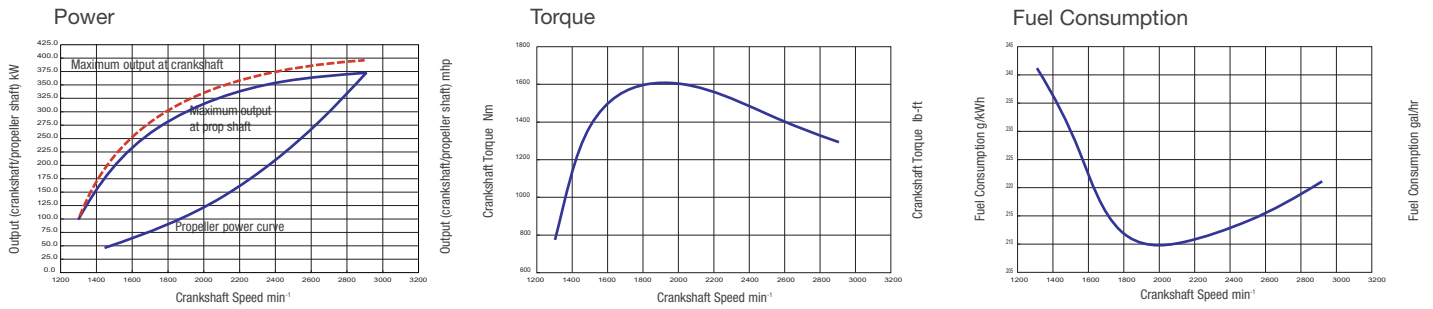

Marine gear

Model	KMH70A			
Type	Multiple disk hydraulic clutch			
Dry weight	77 kg			
Reduction Ratio	2.56	2.07	1.57	1.23
Propeller speed [@2900RPM]	1133	1401	1847	2358
Dry weight engine and gear/drive	914 kg (2015 lb)			

NMEA2000 control system

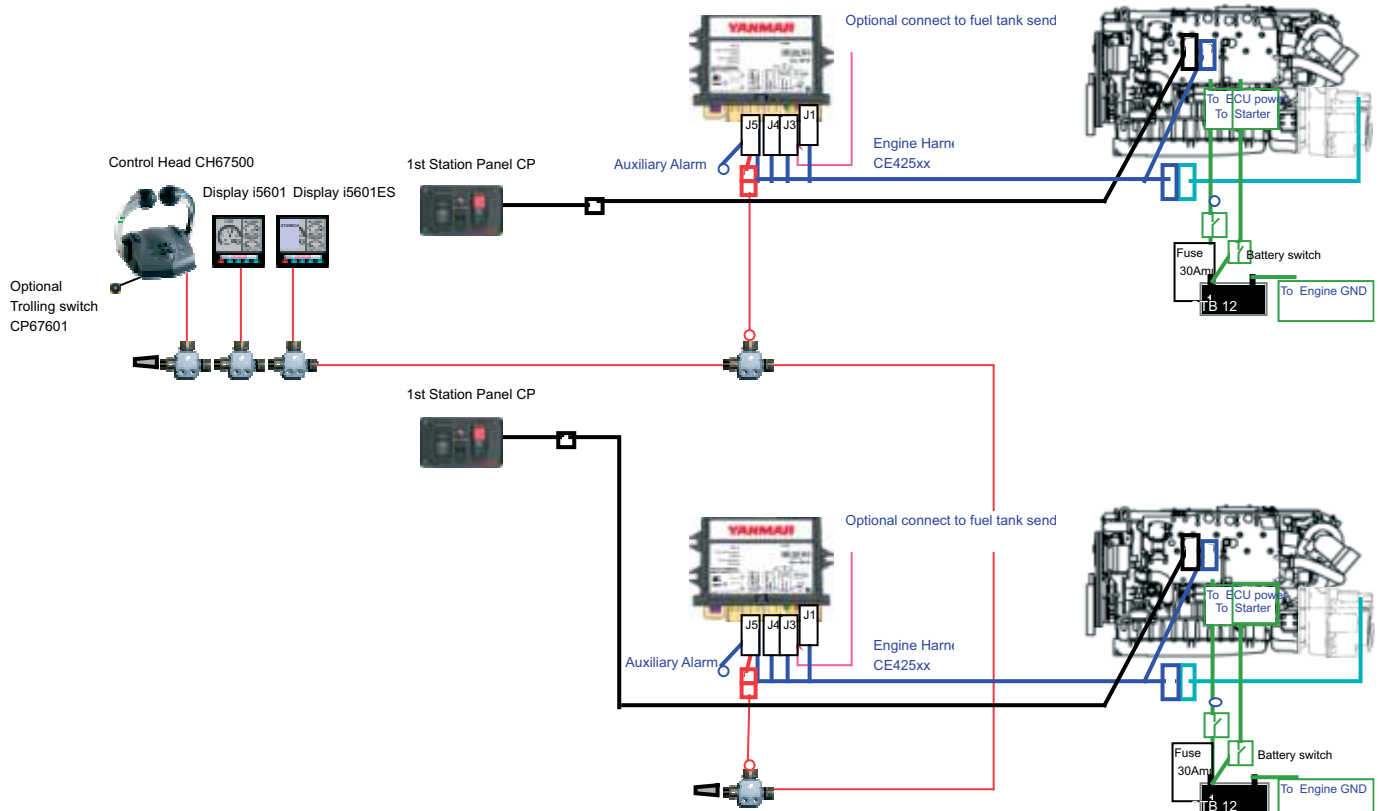

Accessories

Options:

- Flexible mounts
- NMEA2000 Control heads
- NMEA2000 Display and Gauges