

Yanmar type 6SY-650



Configuration	4-stroke, vertical, water cooled diesel engine
Maximum output at crankshaft	* 481 kW (654 mhp) / 2300 rpm
Continuous rating output at crankshaft	479 kW (651 mhp) / 2100 rpm
Displacement	11.7 L (714 cu in)
Bore x stroke	127 mm x 154 mm (5.0 in x 6.1 in)
Cylinders	6 in line
Combustion system	Direct injection
Aspiration	Turbocharged with charge air cooler
Starting system	Electric starting 24 V - 6.7 kW (2 pole)
Alternator	24 V - 65 A (2 pole)
Cooling system	Fresh water cooling by centrifugal fresh water pump and rubber impeller seawater pump
Lubrication system	Enclosed, forced lubricating system
Direction of rotation (crankshaft)	Counter clockwise viewed from flywheel side
Dry weight without gear	1150 kg (2536 lbs)
Environmental	EU RCD, US EPA Tier 2, BSO II & EMC
Engine mounting	Rubber type flexible mounting

NOTE: Fuel condition: Density at 15°C = 0.84 g/cm³; 1 mhp = 1PS = 0.7355 kW = 0.9863 bhp
 * Fuel temperature 40°C at the inlet of the fuel injection pump (ISO 8665)
 Technical data is according to ISO 8665 / 3046

Dimensions (For detailed line-drawings, please refer to our web-site: www.yanmarmarine.com)

Rear view

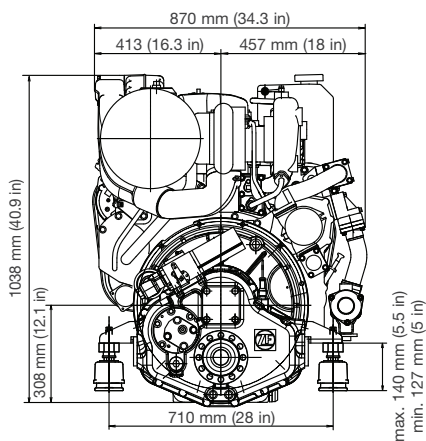

Right side view

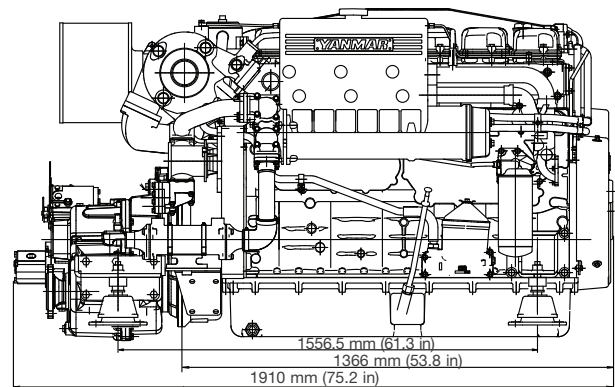

6SY-650 with ZF 325-1 marine gear

Performance Curves (Output is according ISO 8665)

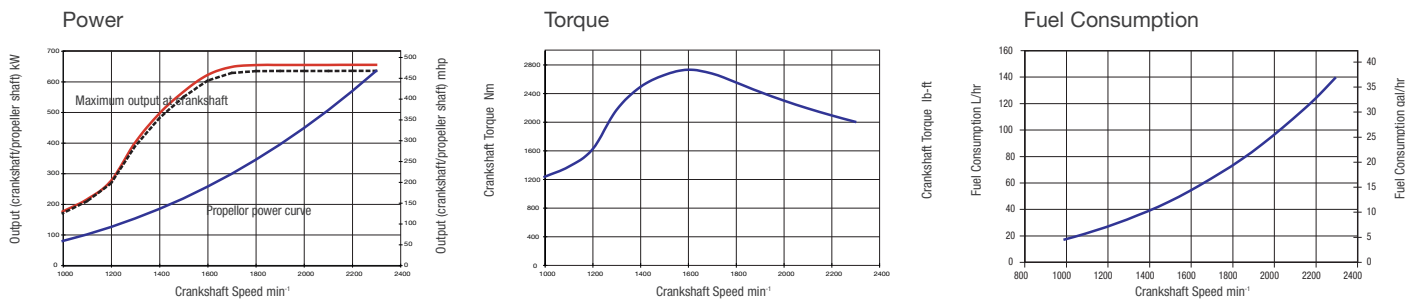

Marine gear (example) ***

Model	ZF 325-1				ZF 325-1A				TD MG 5095SC				TD MG 5095A			
Type	hydraulic				hydraulic				hydraulic				hydraulic			
Dry weight	130 kg (286 lbs)				130 kg (286 lbs)				175 kg (385 lbs)				177 kg (390 lbs)			
Reduction ratio (fwd)	1.46	1.73	2.03	2.25	1.49	1.73	2.04	2.24	1.47	1.71	2.0	2.46	1.52	1.81	2.04	2.48
Propeller speed (fwd)	1575	1329	1133	1022	1544	1329	1127	1027	1565	1345	1150	935	1513	1271	1127	927
Direction of rotation (propeller shaft - fwd)	Clockwise & counter clockwise viewed from flywheel side				Clockwise & counter clockwise viewed from flywheel side				Clockwise & counter clockwise viewed from flywheel side				Clockwise & counter clockwise viewed from flywheel side			
Dry weight engine and gear/drive	1280 kg (2822 lbs)				1280 kg (2822 lbs)				1325 kg (2921 lbs)				1327 kg (2926 lbs)			
Length engine and gear/drive	1910 mm (75 in)				1910 mm (75 in)				1982 mm (78 in)				1987 mm (78 in)			

*** Gear also available in; ZF325-IV (V-drive) reduction ratio: 1.73 & 2.04, TD MG 5114 IV (V-drive) reduction ratio: 1.52, 1.80 & 1.97

*** Other marine gearboxes and configurations available upon request. Contact your local supplier for more information.

Electronic Control System (NMEA 2000 Canbus System)

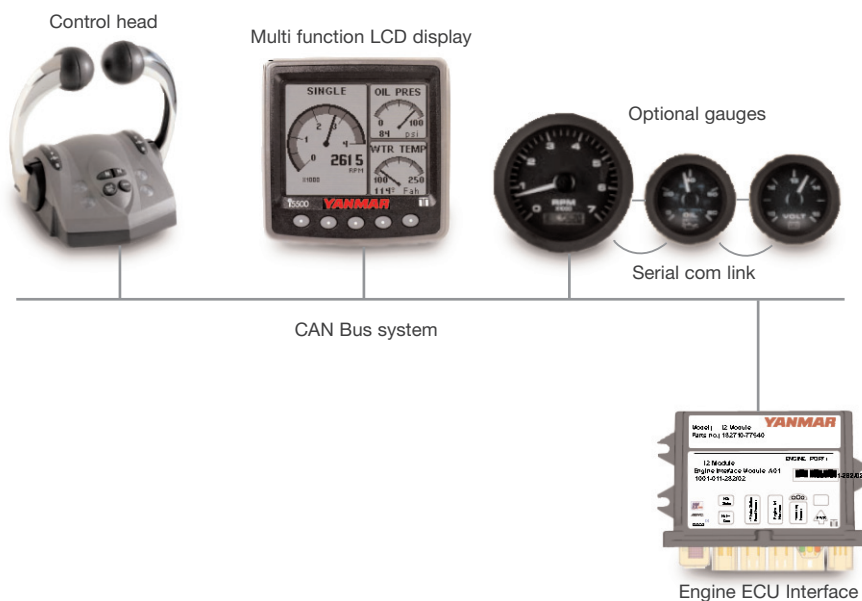

Engine Accessories

Standard Engine Package System

- Alternator
- Protection cover for belt transmission
- Transmission oil cooler
- Water level sensor
- Engine control harness

Optional Engine Package System

- Electric oil draining pump
- Engine heater
- Extra rear PTO
- Hydraulic pump
- Exhaust mixing elbow
- Crankshaft pulley
- Additional alternator

Electronic Control System

Standard Electronic Control

- Electronic Control Head
- LCD display
- Back-up throttle control system

Optional Electronic Control

- Second station control system
- Various engine Monitoring gauges
- Various engine Control heads