

**ASCO**<sup>®</sup> Series 300  
*We Keep Your Power On*<sup>®</sup>

Power Transfer Switches



Where would you be without a constant flow of electrical power? We often take for granted that power will always be around when we need it. In reality, power failures are very common. And when the power goes out, your business suffers. Power failures are unpredictable. They can occur at any time and for any number of reasons—a bolt of lightning, a power surge, a blackout, an accident or even equipment failure. They come without warning and often at the most inconvenient times.

It's for this reason that many businesses and other entities have invested in emergency power backup systems. Typically, the system consists of an engine generator and an automatic transfer switch (ATS) which transfers the load from the utility to the generator.

An ATS with built-in control logic monitors your normal power supply and senses any interruptions. When the utility power fails, the ATS automatically starts the engine and transfers the load after the generator has reached proper voltage and frequency. This happens in a matter of seconds after the power failure occurs. When the utility power has been restored, the ATS will automatically switch the load back, and after a time delay, it will shut down the engine. With an Automatic Transfer Switch, you are protected 24 hours a day, seven days a week.



## Telecom

In the telecommunications industry, providing a high level of service and dependability is crucial. Lost power means an interruption in service for your customers and lost business for your company. For instance, with cell sites scattered across a wide geographical region and in many remote areas, the chances of an interruption in power are increased, making Automatic Transfer Switches a valuable resource at each location. To maintain dependable service, each cell site must be monitored 24 hours a day. This can be very difficult without some type of remote monitoring and testing capability. The Series 300 Transfer Switch, combined with ASCO's monitoring and control management system, is a cost-effective, packaged solution which can help meet both of these challenging objectives without a major investment at each cell site. With ASCO's connectivity solutions you can remotely monitor and control numerous sites from around the corner or around the world.



## Commercial/Retail, Light Industrial

The retail industry is very competitive. An electrical power failure can have a dramatic impact on a retailer's bottom line. If power is interrupted during peak shopping times, the effect could be extremely damaging to present and future business. A power interruption will not only suspend shopping, it can also create safety problems, result in lost transaction data, lost account information and damage to data collection equipment. In addition, retailers who rely on controlled climates to protect valuable inventory could suffer even greater losses, especially if the power failure occurs at a time when no one is available to rectify the situation. To avoid any of these power outage problems, simply install a backup generator with an ASCO Series 300 Transfer Switch and power outage concerns will be a thing of the past.



## Municipal

The ASCO Series 300 Transfer Switch can be a critical component of a municipal government's emergency power backup system. Residents of townships, cities and counties rely on police, fire, ambulance/first aid and other critical public sector services. An interruption in power would affect the ability of emergency services to effectively respond to the needs of the community. When time is a critical factor, such as when responding to a fire alarm or an emergency call, an ASCO Series 300 Transfer Switch can be a lifesaver, switching power to the backup generator. While not all municipal services are a matter of life and death, they are always expected to be there.



## Agriculture

Maintaining electrical power is vital to an agriculture operation. If the flow of power is interrupted, your operation could be at risk unless the backup generator is quickly activated. A prolonged power outage can affect numerous aspects of the operation, from housing and feeding livestock to processing and producing the end product. With an ASCO Series 300 Transfer Switch, power will automatically be transferred over to your backup generator, eliminating the need to manually switch from utility to generator. When power is restored, the ASCO Series 300 Transfer Switch will, after an adjustable time delay to allow for utility stabilization, automatically switch the load back to the utility service.

## Maximum Reliability & Excellent Value

With a Series 300 Transfer Switch, you get a product backed by ASCO Power Technologies, the industry leader responsible for virtually every major technological advance in the Transfer Switch industry.

The ASCO Series 300 was designed for one purpose—to automatically transfer critical loads in the event of a power outage. Each and every standard component was designed by ASCO engineers for this purpose.

The rugged construction and proven performance of the ASCO Series 300 assure the user of many years of complete reliability. The Series 300 is even designed to handle the extraordinary demands placed on the switch when starting or restarting stalled motors and switching high inrush loads.

ASCO's Series 300 modular, compact design makes it easy to install, inspect and maintain. All parts are accessible from the front so switch contacts can be easily inspected.

## Features

- The Series 300 is listed to UL 1008 standard for Transfer Switch Equipment and meets NFPA 110 for Emergency and Standby Power Systems and the National Electrical Code (NEC) Articles 700, 701 and 702. CSA listings are also available.
- 30 through 3000 amps in a compact design.
- Available to 600 VAC, single or three phase.
- True double-throw operation: The single solenoid design is inherently interlocked and prevents contacts from stopping between sources or from being in contact with both sources at the same time.

## UL Listed Withstand & Close-On Ratings

Switch Ratings amps	Available Symmetrical Amperes RMS at 600 VAC	
	When Used With Current Limiting Fuses	When Used With Specific Circuit Breakers
30	100,000	10,000
70, 100, 104, 150	200,000	22,000
200 (240 V Max.)	200,000	22,000
225, 260, 400	200,000	42,000
600, 800, 1000, 1200	200,000	65,000
1600, 2000	200,000	85,000
2600, 3000	200,000	100,000

**Note:** Current-limiting fuse should be Class J type through 400 amps: use class L type above 400-amp fuse rating.



**Fig. 1:** ASCO Power Transfer Switch rated 200 amperes shown in Type 3R enclosure

- There's no danger of the Series 300 ATS transferring loads to a dead source because the unique ASCO single-solenoid operator derives power to operate from the source to which the load is being transferred.
- Easy-to-read flush-mounted control and display panel provides LED indicators for switch position and source availability. It also includes test and time-delay bypass switches as standard features.
- Standard engine exerciser for weekly automatic testing of engine generator set with or without load.
- Adjustable time-delay feature prevents switch from being activated due to momentary utility power outages and generator dips.
- Supplied with solid neutral termination. Optional switched neutral pole available.
- Accessory kits available.
- Available for immediate delivery.
- Now available for service entrance applications. Contact ASCO for assistance.

## Designed to Fit Anywhere

The ASCO Series 300 product line represents the most compact design of automatic power transfer switches in the industry. With space in electrical closets being at a premium, the use of wall or floor-mounted ASCO Power Transfer Switches assures designers optimum utilization of space.

All transfer switches through 2000 amps are designed to be completely front accessible. This permits the enclosures to be installed flush to the wall and still allows installation of all power cabling and connections from the front of the switch. Cable entrance plates are also standard on the 1600 and 2000 amp units to install optional side-mounted pull boxes for additional cable bending space.



**Fig. 4:** ASCO Power Transfer Switch rated 1000 amperes



**Fig. 2:** ASCO Power Transfer Switch rated 200 amperes



**Fig. 5:** ASCO Power Transfer Switch rated 2000 amperes shown in Type 3R enclosure



**Fig. 3:** ASCO Power Transfer Switch rated 400 amperes



**Fig. 6:** ASCO Power Transfer Switch rated 3000 amperes

The ASCO Microprocessor Controller is used with all sizes of Power Transfer Switches. It represents the most reliable microprocessor controller in the industry and includes, as standard, all of the voltage, frequency, control, timing and connectivity functions required for most emergency and standby power applications.



**Fig. 7:** ASCO Series 300 Microprocessor Controller

## Voltage & Frequency Sensing

- Adjustable three-phase, close-differential voltage sensing on normal source.
- Normal source pickup voltage is adjustable to 95% of nominal; drop-out is adjustable from 70% to 90% of nominal.
- Frequency sensing on emergency source. Pickup at 95% and dropout at 85% of nominal.

## Time Delays

- Adjustable time delay to override momentary normal source outages to delay all transfer switch and engine-starting signals.
- Transfer to emergency time delay—Adjustable from 0 to 5 minutes for controlled timing of load transfer to emergency.
- Retransfer to normal time delay—Adjustable to 30 minutes.
- Five-minute unloaded running time delay for emergency engine generator cool down.
- Four-second time delay to ignore momentary voltage and frequency transients during initial genset loading.

## Standard Selectable Features

- Inphase monitor to transfer motor loads, without any intentional off time, to prevent inrush currents from exceeding normal starting levels.
- Engine exerciser to automatically test backup generator each week—Includes control switch for testing with or without load.
- Selective load disconnect, double-throw contact to operate at an adjustable 0 to 20 second adjustable time delay prior to transfer and reset 0 to 20 seconds after transfer.
- 60 Hz or 50 Hz selectable switch.
- Three-phase/single-phase selectable switch.



**Fig. 8:** Door-Mounted Control & Display Panel

## Control and Display Panel

- Easy-to-read flush-mounted control and display panel provides LED indicators for switch position and source availability. It also includes test and time-delay bypass switches.

## Remote Control Features

Terminal provisions for connecting:

- Remote test switch.
- Remote contact for test or for peak shaving applications. Circuit will be automatically bypassed if emergency source fails.
- Inhibit transfer to emergency.
- Remote time-delay bypass switch.

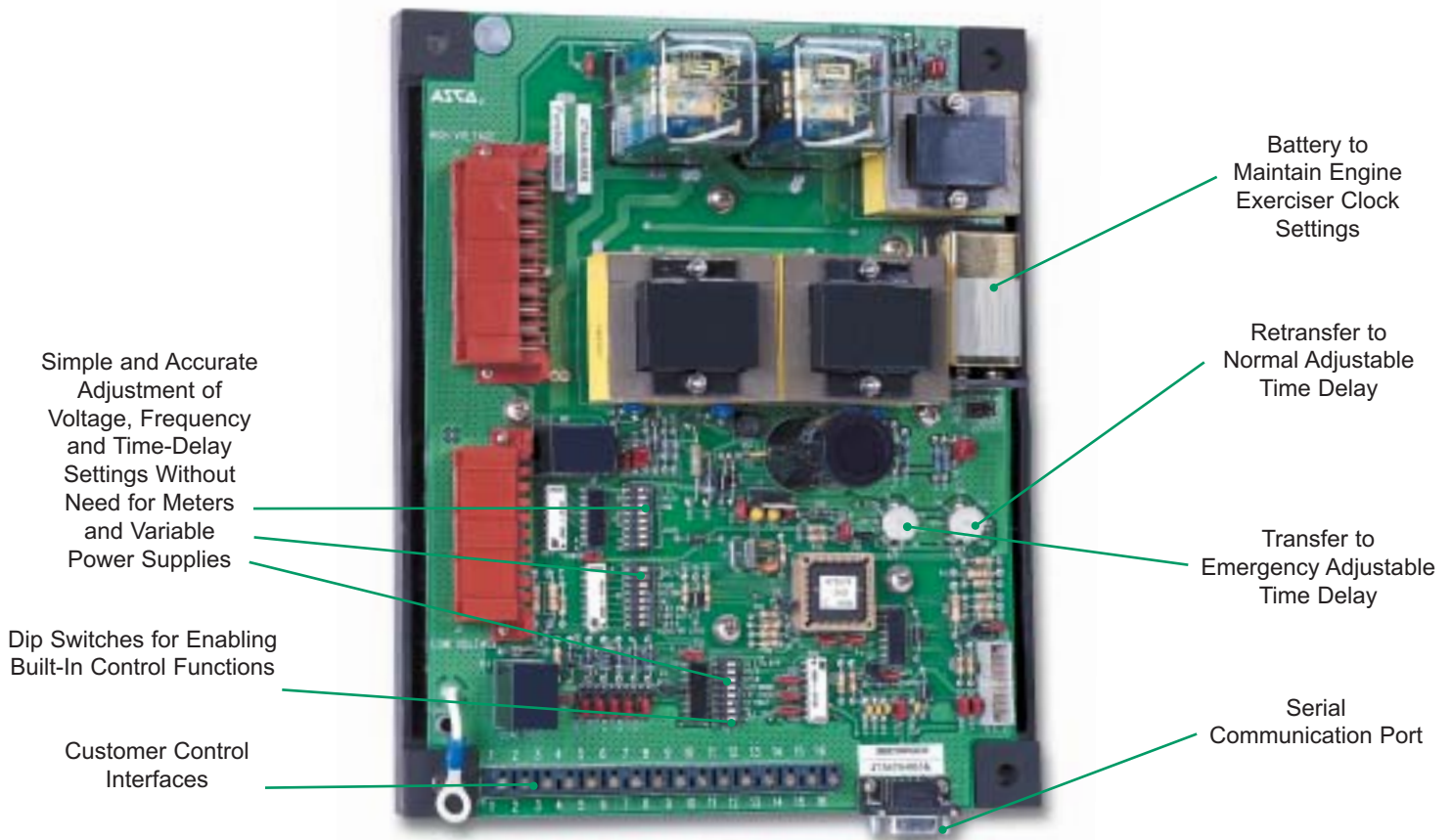

**Fig. 9:** Microprocessor Controller

## Performance Features

- 600 volt spacing per UL and CSA standards.
  - Interfacing relays are industrial grade, plug-in type with dust covers.
  - Meets or exceeds the requirements for Electromagnetic Compatibility (EMC).
- |   |  |
|---|--|
| <ul style="list-style-type: none"> <li>● ANSI C37.90A/IEEE472 Voltage Surge Test</li> <li>● NEMA ICS-109.21 Impulse Withstand Test</li> <li>● Digital circuitry isolated from line voltages</li> <li>● IEC 801-2 Electrostatic discharge (ESD) immunity</li> <li>● ENV50140 and IEC 803-1: Radiated electromagnetic field immunity</li> </ul> | <ul style="list-style-type: none"> <li>● IEC 801-4 Electrical fast transient (EFT) immunity</li> <li>● ENV50142 Surge transient immunity</li> <li>● ENV50141: Conducted radio-frequency field immunity</li> <li>● EN55011: Group 1, Class A conducted and radiated emissions</li> <li>● Optically isolated RS-485 Serial Port</li> </ul> |
|---|--|

## Accessory 11CD

Deluxe programmable engine exerciser provides ability to uniquely program each day of the week, or blocks of days from one minute to 24 hours with digital readout convenience. Includes “with or without” load control switch for exercise period. Load indicator in display to show if exerciser is ON or OFF. Timer also includes a permanent battery to maintain settings when normal and emergency power is lost.

## Accessory 14AA/14BA

Auxiliary contacts to indicate position of main contacts. Two (2) for normal and two (2) for emergency position (one set is standard).

## Accessory 44A

Strip Heater with thermostat for extremely cold areas to prevent condensation and freezing of this condensation. External 120 volt power source required.

## Accessory 44G

Strip Heater with thermostat, wired to load terminals: 208-240, 360-380, 460-480, 550-600 volts. Contains wiring harnesses for all transfer switch sizes.

## Accessory 72A

Communications Interface Module (RS-485) to allow local or remote communications with ASCO PowerQuest® VPi or SiteWeb™ communication products.

## ASCO Pulsar® 450 High-Performance Surge Suppressor

The ASCO Pulsar® 450 provides unparalleled protection from power surges and transients. It is a high-performance surge suppressor which limits large surges and transients through a unique array of computer-matched metal oxide varistors (MOVs). Unique four-cavity sand packed UL94-5 volt rated housing, UL1449, UL1283, and CSA listed. Available as a separate product only for mounting by customer. Contact ASCO for ordering information.

## Field Conversion Kits for Series 300 Transfer Switches

Kit No.	Description
K601111	Deluxe Engine Exerciser Kit (Acc. 11CD)
K613127-001	Strip Heater Kit (125 watt) 120 volt (Acc. 44A)
K613127-002	Strip Heater Kit (125 watt) 208-480 volt (Acc. 44G)
K609027	Cable Pull Box (1600-2000 amp)



**Fig. 10:** Deluxe Engine Exerciser (Accessory 11CD)



**Fig. 11:** Strip Heater Kit (Accessory 44G)



**Fig. 12:** Pulsar 450 Surge Suppressor

## User-Initiated Control

ASCO 386 non-automatic transfer switches are generally used in applications where operating personnel are available and the load is not an emergency type requiring automatic transfer of power. The power-switching mechanism and controller is the same hardware used on the highly reliable ASCO Series 300 transfer switches. ASCO 386s are furnished as standard with a momentary-type selector switch to initiate transfer and retransfer. They can also be arranged for remote control via ASCO's communication products.



**Fig. 13:** ASCO 386 400 Amp Type 1 Enclosure w/Optional Accessories 9C, 9D Source Availability Lights



**Fig. 14:** Control and Display Panel

## Electrical Features:

- Listed under UL 1008, CSA certified:
  - UL listed through 480 VAC.
  - CSA certified through 600 VAC.
- Door-mounted selector switch for local, manually initiated electrical control.
- Sizes from 30 through 3000 amps.
- Available to 600 VAC, 50 or 60 Hz.
- Rated for all classes of load transfer.
- 100% tungsten load ratings through 400 amps.
- Designed for emergency and standby applications.
- Same withstand and close-on rating as Series 300.

## Standard Selectable Control Features:

- Inphase monitor to transfer motor loads between live sources, without any intentional off time, to prevent inrush currents from exceeding normal starting levels.
- Selective load disconnect, double-throw contact to operate at an adjustable 0 to 20 second time delay prior to transfer and reset 0 to 20 seconds after transfer.
- High/Low nominal voltage setting. Allows user to adjust for source low reduced voltage conditions in remote areas.
- 60 Hz or 50 Hz selectable switch.
- Single/Three-phase selectable switch.

## Control Features:

- Switch position indicating signal lights.
- One auxiliary contact closed when transfer switch is connected to normal and one closed on emergency, standard feature 14A/14B.

## Optional Accessories:

- 6Q Key-operated, momentary source selector switch furnished instead of the standard selector switch.
- 9C, 9D Source availability lights to provide operator with a local indication of power source availability.
- Accessory 14AA/14BA auxiliary contacts to indicate position of main contacts. Two (2) for normal position and two (2) for emergency position (one set is standard).
- 72A Communications interface module (RS-485) to allow local or remote communications with ASCO PowerQuest® VPi or SiteWeb™ communication products.
- Special Enclosures (Specify by appropriate code in catalog number):
  - Type 3R: Raintight
  - Type 4: Weatherproof
  - Type 12: Oil Tight



## ASCO Connectivity Solutions

ASCO PowerQuest® and SiteWeb™ communications products allow for the monitoring and control of power transfer switches in your Emergency or Standby Power Distribution System. Local Area Networks and Remote networks are supported with either single or multiple points of access, and web-enabled communications allow access to your power system from anywhere around the world.

### Features

- Monitors and Controls Power Transfer Switches and Engine Generators
- Monitors Normal and Emergency Voltages and Frequency
- Indicates Transfer Switch Position and Source Availability
- Provides Transfer and Retransfer of Loads for System Testing
- View Normal and Emergency Voltage and Frequency Settings
- View Transfer Switch Time-Delay Settings
- Provides Transfer Switch Rating and Identification
- Automatic Paging Notifies Personnel, by E-mail or Pager, of Selected System Alarms
- View Current, Power and Power Factor with ASCO Power Managers Connected to the System

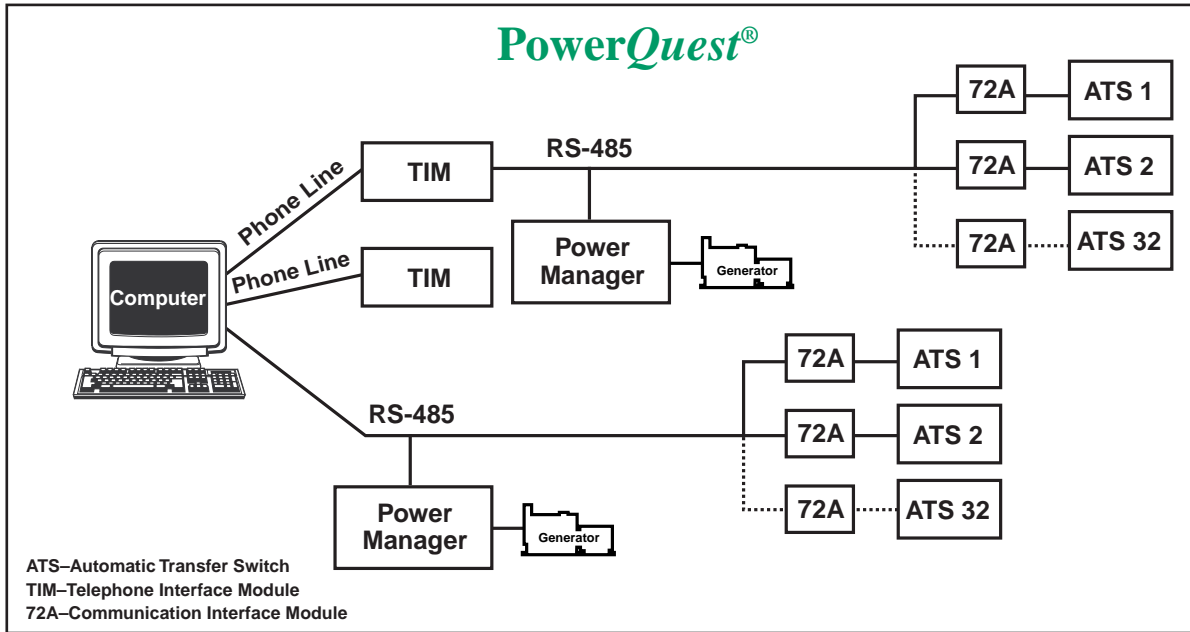

PowerQuest® VPi is a PC based software package. When combined with the ASCO Communication Interface Module (Acc 72A), the ASCO 5120 Telephone Interface Module and ASCO 5200 Series Power Manager, as shown above, it provides the most economical communication system for monitoring and control of power transfer switches and engine generators.

The local RS-485 network allows communications with up to 32 power transfer switches and four engine generators. An analog phone connection and ASCO telephone interface module allow for direct dial up, monitoring and control of remote locations. The ASCO Power Manager not only allows you to view current power and power factor readings, but also has a programmable KW set point to initiate transfer of loads to a standby source for peak shaving operations.

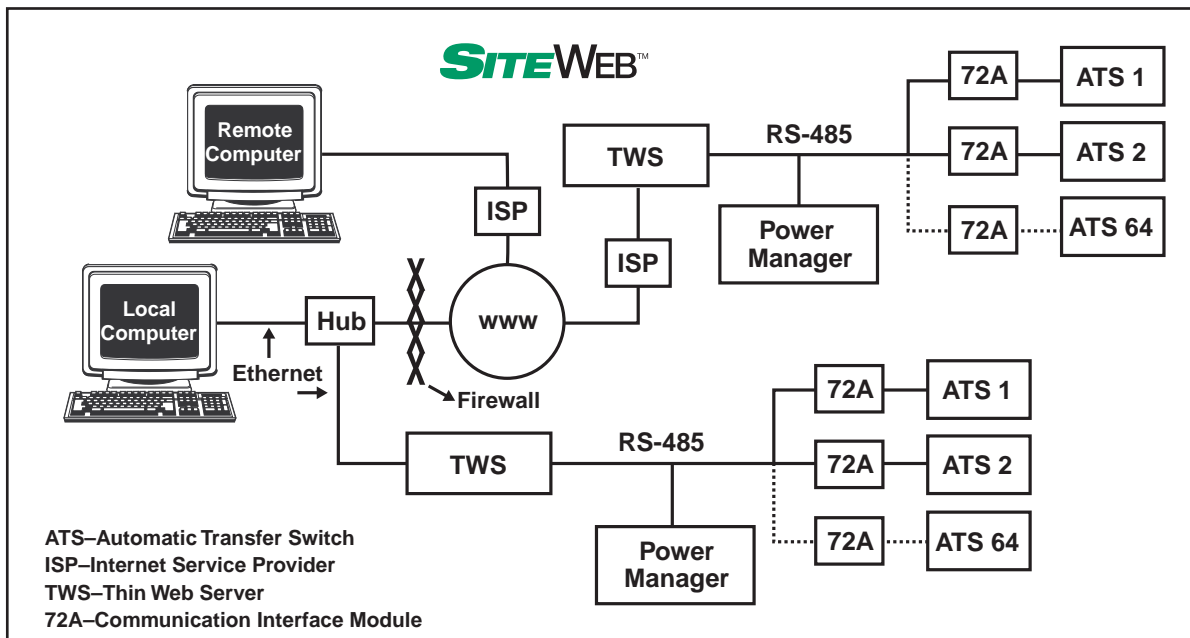

SiteWeb™ is a client-server application requiring no software to be installed on the client computer. When combined with the ASCO Communication Interface Module (Acc 72A), the ASCO 5500 Series Thin Web Server and the ASCO 5200 Series Power Manager, as shown above, it provides the most comprehensive Intranet and Internet communication system for the monitoring and control of power transfer switches and engine generators located in your emergency or standby power distribution system.

The SiteWeb™ communication system allows multiple client access, from local or remote locations, and provides for the monitoring of up to 64 power transfer switches and eight engine generators. In addition, automatic paging is provided for all alarm signals.

## PowerQuest® VPi vs. SITEWEB™

Feature	PowerQuest VPi 32.15	SITEWEB™
Number of Monitored/Controlled Power Transfer Switches	32	64
Number of Monitored/Controlled Gensets	4	8
Web Access	No	Yes
Monitor Multiple Sites	Yes	Yes
Multiple Client Access	No	Yes
Client Software Required	Yes	No
Email / Paging upon Alarms	No	Yes

### Communication Interface Module (Acc 72A)

Communication Interface Module to allow local, remote or web-enabled communications with ASCO PowerQuest® VPi or SiteWeb™ communication products. An accessory 72A is required on each power transfer switch.



Fig. 16: Communication Interface Module



Fig. 17: Telephone Interface Module

### 5100 Series Telephone Interface Module (for use with PowerQuest® VPi)

The ASCO Telephone Interface Module (TIM) allows users to dial directly into their ASCO communications network for monitoring and/or control. The TIM connects to the ASCO communication network via RS-485 and the phone port connects directly into an analog phone jack. Also, the TIM has an RS-232 connector which allows the TIM to be used as the dialing modem.

Supplied with 120 VAC to 18 VDC (nominal) UL approved, class 2 power supply.





Fig. 18: Thin Web Server

## 5500 Series Thin Web Server (for use with **SITEWEB**™ products)

The ASCO Thin Web Server allows you to monitor and control transfer switches and engine generators anytime over the Internet or an Intranet from anywhere in the world. It also transmits a page message that an alarm has occurred with one or more of the transfer switches. Plus, this is possible from your home computer or anywhere that has Internet service, using the ASCO Thin Web Server single-board computer with its embedded *SiteWeb* HTML web pages.

## 5200 Series Power Manager

The ASCO 5200 Series Power Manager is a microprocessor metering device specifically designed for transfer switch applications to provide real-time measurements of single and three-phase power systems. It uses digital signal processing technology to measure voltage and phase currents, which it uses to calculate real, reactive, and apparent power and bi-directional energy. All measurements can be displayed locally or at a remote PC via *PowerQuest*® or *SiteWeb*™. It can also collect data for both normal and emergency positions using auxiliary contact inputs from the transfer switch. Eight digital input and four digital outputs available for customer use.



Fig. 19: ASCO 5200D Series Power Manager

## Communications Products for Series 300 Transfer Switches

Description	Acc. Option	Catalog No.
Communication Interface Module	72A	—
Telephone Interface Module for Remote Monitoring*	—	5120
Power Manager with Display*	—	5200D
Thin Web Server*	—	5510E
Thin Web Server with Modem*	—	5510M
PowerQuest VPi Software Package*	—	VPi 32.15

\*Note: These products are available as separate items only. They can be ordered by catalog numbers shown in above chart.



# Dimensions & Shipping Weights for ASCO® Series 300 & 386 Transfer Switches

## UL Type 1 Enclosure (See notes below for information on Type 3R, 4 & 12 Enclosures)

Switch Rating amps	Phase Poles	Neutral Code	Dimensions, In. (mm) <sup>3</sup>			Approx. Shipping Weight Lb. (kg) <sup>4</sup>
			Width	Height	Depth	
30, 70, 100, 104	2	A	17 1/2 (445)	31 (787)	11 5/8 (295)	67 (31)
	2	B	17 1/2 (445)	31 (787)	11 5/8 (295)	70 (32)
	3	A	17 1/2 (445)	31 (787)	11 5/8 (295)	70 (32)
	3	B	17 1/2 (445)	31 (787)	11 5/8 (295)	73 (33)
150, 200	2	A	17 1/2 (445)	31 (787)	11 5/8 (295)	69 (32)
	2	B	17 1/2 (445)	31 (787)	11 5/8 (295)	72 (33)
	3	A	17 1/2 (445)	31 (787)	11 5/8 (295)	72 (33)
	3	B	17 1/2 (445)	31 (787)	11 5/8 (295)	75 (34)
225, 260, 400	2	A	18 (457)	48 (1219)	13 (330)	117 (53)
	2	C	18 (457)	48 (1219)	13 (330)	125 (57)
	3	A	18 (457)	48 (1219)	13 (330)	125 (57)
	3	C	18 (457)	48 (1219)	13 (330)	133 (61)
600, 800, 1000	2	A	34 (864)	72 (1829)	20 (508)	400 (182)
	2	B	34 (864)	72 (1829)	20 (508)	420 (192)
	3	A	34 (864)	72 (1829)	20 (508)	420 (192)
	3	B	34 (864)	72 (1829)	20 (508)	446 (203)
1200	2	A	38 (965)	87 (2210)	24 (610)	685 (312)
	2	B	38 (965)	87 (2210)	24 (610)	705 (321)
	3	A	38 (965)	87 (2210)	24 (610)	705 (321)
	3	B	38 (965)	87 (2210)	24 (610)	734 (333)
1600, 2000 <sup>1</sup>	3	A	38 (965)	87 (2210)	24 (610)	955 (433)
	3	B	38 (965)	87 (2210)	24 (610)	1005 (455)
2600, 3000 <sup>2</sup>	3	A	38 (965)	91 (2311)	60 (1524)	1395 (633)
	3	B	38 (965)	91 (2311)	60 (1524)	1460 (663)

## Series 300 & 386 External Power Connections

Sizes UL-Listed Solderless Screw-Type Terminals

Switch Rating (amps)	Ranges of AL-CU Wire Sizes (Unless Specified Copper Only)
30, 70, 100, 104	One #14 to 2/0 AWG
150	One #8 to 3/0 AWG
200	One #8 to 3/0 AWG CU Only
225, 260, 400	Two 1/0 AWG to 250 MCM or One #4 AWG to 600 MCM
600	Two 1/0 AWG to 600 MCM
800, 1000, 1200	Four 1/0 to 600 MCM
1600, 2000	Six 1/0 to 600 MCM
2600	Twelve 3/0 to 600 MCM
3000	Twelve 3/0 to 600 MCM

**Note:** All Series 300 switches are furnished with a solid neutral plate (unless switched neutral configuration is specified) and terminal lugs. Specify "A" in catalog number to order a neutral plate on the series 386 switches.

### Notes:

- Unit is designed for top cable entry of emergency & load and bottom entry of normal. A cable pull box is also available for all top or bottom cable access when required (optional accessory kit #K609027). Not required for type 3R, 4 & 12 enclosures where available.
- Enclosures for 2600, 3000 amps are free-standing with removable top, sides & back.
- For type 3R, 4 & 12 dimensions, add the following values to the type 1 dimensions:
  - 30, 70, 100, 104, 150, 200A—add 1.5 in (38 mm) to the height.
  - 400, 600, 800, 1000A—add 1.5 in (38 mm) to the depth.
  - 1200A—type 4 & 12 not available—use 1600 amp switch
  - 1600A—add 3 in (76 mm) to the height and 10 in to (253 mm) to the width.
  - 2000, 2600, 3000A—type 4 & 12 not available. (Consult ASCO) Type 3R add 4.68 in (118 mm) to the height add 2.0 in (51 mm) to the width and add 13 in (329 mm) to the depth.
- For type 3R, 4 & 12 weights, add the following values to the type 1 weights:
  - 30, 70, 100, 104, 150, 200A—add 15 lbs. (6.8 kg).
  - 400, 600, 800, 1000A—add 40 lbs. (18.1 kg).
  - 1600A—add 60 lbs. (27 kg).
  - 2000A–3000A Type 4 & 12 not available. (Consult ASCO)
- When temperatures below 32°F can be experienced, special precautions should be taken, such as the inclusion of space heaters, to prevent condensation and freezing of this condensation. This is particularly important when environmental enclosures (Type 3R, 4 & 12) are ordered for installation outdoors.

## Ordering Information for ASCO® Series 300 & 386 Transfer Switches

To order an ASCO Series 300 Power Transfer Switch, complete the following catalog number:

300 + B + 3 + 600 + N + 1 + X + C + 11CD + 480 V 60 Hz											
Product	Neutral Code	Poles	Amperes	Voltage Code		Controller	Options	Enclosure		Optional Accessories	Specific Volt & Freq
				Blank	Open Type						
300	Blank Solid Neutral  B <sup>1</sup> Switched Neutral	2 poles, 1Ø  3 poles, 3Ø	Continuous rating  30, 70, 104, 150, 200 <sup>2</sup> , 225, 260, 400, 600, 800, 1000, 1200, 1600, 2000 2600, 3000	A <sup>4</sup> B <sup>4</sup> C D E F H J K L M N Q R	115 120 208 220 230 240 380 400 415 440 460 480 575 600	1	Insert "X" If optional accessories are required	C  F  G  L	Type 1 (Standard)  Type 3R Enclosure  Type 4 Enclosure <sup>3</sup>  Type 12 Enclosure <sup>3</sup>	11CD Deluxe Engine Exerciser  14AA/14BA Auxiliary Contacts (2 sets)  44A, 44G Strip Heater w/Thermostat  72A Comm Interface Module	This information is necessary to allow correct control settings prior to shipment

To order an ASCO Series 386 Transfer Switch, complete the following catalog number:

386 + B + 3 + 600 + N + 1 + X + C + 9C/9D + 480 V 60 Hz											
Product	Neutral Code	Phase Poles	Amperes	Voltage Code		Controller	Options	Enclosure		Optional Accessories	Specific Volt & Freq
				Blank	Open Type						
386	A Solid Neutral  B <sup>1</sup> Switched Neutral	2 poles, 1Ø  3 poles, 3Ø	Continuous rating  30, 70, 100, 150, 260, 400, 600, 800, 1000, 1200, 1600, 2000, 3000	A <sup>4</sup> B <sup>4</sup> C D E F H J K L M N Q R	115 120 208 220 230 240 380 400 415 440 460 480 575 600	1	Insert "X" If optional accessories are required	C  F  G  L	Type 1 (Standard)  Type 3R Enclosure  Type 4 Enclosure <sup>3</sup>  Type 12 Enclosure <sup>3</sup>	6Q Key-Operated Control  9C/9D Source Availability Lights  14AA/14BA Auxiliary Contacts  72A Comm Interface Module All Accessories	This information is necessary to allow correct control settings prior to shipment

- Note:**
1. Specify neutral code "C" for 225, 260, and 400 amperes only.
  2. 200 amps limited to 240 volts.
  3. Available 30-1600 ampacity. Use Type 3R for 2000-3000 amp applications.
  4. 115-120 volt available 30-400 amps only. For other voltages contact ASCO.
- Consult ASCO for special ordering when a CSA label is required.

### Extended Warranties for Series 300 Transfer Switches

Catalog No.	Description
2EXW300	Two-Year Extended Warranty (Parts & Labor)
3EXW300	Three-Year Extended Warranty (Parts & Labor)
4EXW300	Four-Year Extended Warranty (Parts & Labor)
5EXW300	Five-Year Extended Warranty (Parts & Labor)



## Start-Up, Commissioning, Service & Preventive Maintenance

ASCO Services, Inc., provides a wide range of technical services to users of automatic transfer switches in emergency and standby power systems. These services include comprehensive preventive maintenance programs, modifications, upgrades and emergency repairs. Systems serviced range in complexity from a single automatic transfer switch to multiple transfer switches and engine generators.

ASCO Services is a wholly owned subsidiary and the exclusive OEM service arm of ASCO Power Technologies, the world's largest manufacturer of power transfer switching and control equipment. Serving the needs of ASCO's customers is a major focus; however, ASCO Services is also routinely called upon to perform regular maintenance and emergency repairs on equipment manufactured by others.

ASCO Services offers comprehensive maintenance agreements that detail the preventive care needed to keep emergency power systems ready to respond. A service agreement is an effective way to budget in advance and avoid unexpected expenditures. A 35-point checklist is utilized to assure critical systems and components are kept in top operating condition. These preventive programs can be customized for national accounts.



This customization permits central corporate control of costs and scheduling. Periodic reports provide detailed information as to activity, maintenance performed and corrective action.

ASCO Services deploys more than 75 service personnel strategically located throughout the nation to provide 24-hour response in emergency situations. Each region is manned by experienced personnel who receive ongoing support and training in the newest equipment concepts, design and controls. Because equipment can be utilized for a long number of years, field representatives also receive education on older designs. This knowledge can be invaluable in addressing total system concerns, evaluating problems and providing solutions on site. Service vans are equipped with parts and advanced testing equipment that facilitate these on-the-spot repairs.

**ASCO** Services 1-800-800-ASCO.



ASIA • AUSTRALIA • BRAZIL • CANADA • GERMANY • JAPAN • MEXICO • SOUTH AFRICA • UNITED ARAB EMIRATES • UNITED KINGDOM • UNITED STATES

**ASCO** Power Technologies

800-937-ASCO • [www.asco.com](http://www.asco.com) • Florham Park, New Jersey 07932 USA